



IMPORTANT
WARRANTY ENCLOSED
for
CF/CR5/CFD/CRD5 SERIES

This cooler has passed the
QUALITY CONTROL INSPECTION
and meets the high standards at
Beverage-Air. This inspection includes
complete refrigeration system, cabinet
construction & finish.

☆ _____
Quality Control Inspector—Beverage-Air



WARRANTY REGISTRATION CARD

Cabinet Serial No. _____

Original Purchaser: _____

Address _____
CITY STATE

Installation Location _____
NAME

ADDRESS _____

Beverage-Air Model No. _____ Installation Date _____

This card must be mailed within 10 days after installation date to

BEVERAGE-AIR®

90 Days
Labor Warranty

BEVERAGE-AIR. LIMITED WARRANTY

5 Years
Compressor Warranty

Beverage-Air warrants to the original purchaser the "BEVERAGE-AIR" unit sold and all parts thereof to be free from defects in material or workmanship, under normal use and service, for a period of one (1) year from the date of registration, or fifteen (15) months from date of shipment by us, whichever is earlier.

Our obligation under this warranty shall be limited to repairing or replacing f.o.b. factory any part of such product which proves thus defective and which our examination shall disclose to our satisfaction to be defective.

- a. Any part returned to the company under the terms of this warranty must be accompanied by a record of the cabinet model, serial number and return authorization number, and such return shall be on the basis of TRANSPORTATION CHARGES PAID.
- b. Improper operation due to low voltage conditions, inadequate wiring, and accidental damage are not manufacturing defects and are strictly the responsibility of the purchaser.
- c. Condenser coils must be cleaned at regular intervals. Failure to do so can cause compressor malfunction, and will void warranty. This contract does not apply outside the limits of Continental United States, nor does it apply to any part which has been subject to misuse, neglect, alteration, accident, or to any damage caused by transportation, flood, fire or the acts of God.

This contract is not effective unless the Beverage-Air Warranty Registration Card, furnished with each Unit, is properly filled in and mailed to Beverage-Air within ten (10) days from date of installation.

The term "original purchaser" as used herein shall be deemed to mean that person, firm, association or corporation for whom the Refrigeration Unit referred to herein is originally installed.

ADDITIONAL FOUR-YEAR COMPRESSOR REPLACEMENT WARRANTY

In addition to the warranty set forth above, Beverage-Air warrants the hermetically sealed compressor for an additional four (4) years, not to exceed sixty (60) months from date of shipment from our plant provided, upon receipt of the compressor, manufacturer examination shows the sealed compressor to be defective. This extended warranty does not apply to any electrical controls, condenser, evaporator, fan motors, overload switch, starting relay, temperature control, dryer, accumulator, or wiring harnesses which items are covered by the standard warranty.

No claims can be made against this warranty for spoilage of products.

These warranties are in lieu of all other warranties, express or implied, and all other obligations or liabilities on our part, and we neither assume nor authorize any other person to assume for us any other obligation or liability in connection with the sale of said Refrigeration Units or any part thereof. This warranty shall not be assignable and shall be honored only in so far as the original purchaser.

Date _____

1.88

RETAIN THIS PORTION FOR YOUR RECORDS

PLACE
POSTAGE
HERE

BEVERAGE-AIR.

P.O. BOX 5932
SPARTANBURG, SC
29304-5932



BEVERAGE-AIR®

Installation and Operating Instructions

MODEL: CF/CR5 and CFD/CRD5

1. INSTALLATION:

- a. Receiving Inspection:
Upon receipt, check all packages for accessories or components including legs and shelves.
- b. Legs: (Optional)
To install legs, tip or raise the cabinet one side at a time and remove skid base by removing (2) 5/16-18 hex head bolts. Screw-on legs mount directly into 5/16-18 weld nut provided in each corner at the bottom. (See Fig. 1)
- c. Leveling:
To provide adequate condensate drainage, proper door alignment and operation, it is necessary that the cabinet be level. If levelers are used, the cabinet must be sealed to the counter around the perimeter of the cabinet base with an N.S.F. listed silicone such as Dow Corning #732. (See Fig. 4)
- d. Shelves:
Shipped inside each cabinet are shelves packed in plastic and a bag of shelf supports. Shelf spacing is adjustable to suit requirements. Three (3) shelves come with each cooler, shelves (17 5/16 X 18 7/8) are adjustable from top to bottom.
- e. Door Removal and Adjustment:
Swing Door - Glass or Solid - If door removal is necessary, (remove sign by lifting up and out, CF Model only disconnect power) hold door securely and remove top hinge by unscrewing two (2) 1/4-20 hex head screws. Remove hinge from cabinet and lift door off bottom hinge. Replace door by reversing above method. Adjust Door - Bottom hinge is adjustable. Simply loosen the screws that hold the hinge to the cabinet, the top hinge and the bottom hinge have two (2) 1/4-20 hex head screws. By loosening the bottom hinge the door is adjustable up and down. (See Fig. 2 for Door Removal)
- f. Locating Cooler:
Provide at least three inches of space between cabinet and any adjacent wall or fixture, at rear of cabinet.

2. OPERATION:

- a. Electrical Supply and Connections:
Plug all standard models into 115 volts A.C. 60 hertz outlet. Low line voltage is often the cause of service complaints. Check to see that the line voltage is 110 volts or more with the unit running. Other motors or heavy appliances should not be used on the same circuit with the cooler. When working on the inside of the cooler disconnect from electrical circuit for safety reasons. **CAUTION:** If an extension cord is necessary, use only a three wire grounding type of wire size 16 AWG or larger; do not exceed 20 ft. in length. The use of ungrounded cords or overloaded circuit voids compressor warranty.
- b. Initial Start-Up:
Turn power on and check to verify that the condenser fan is running.
- c. Temperature Control:
Factory setting of temperature control for a refrigerator is No. 4 position (normal) which will maintain the product at about 38°. Factory setting for a freezer is No. 4 position (normal) which will maintain the product at about 0°. For colder temperatures, turn knob clockwise one number at a time.

Excessive tampering with temperature control could lead to service difficulties. For operation above 3000 ft. altitude, have thermostat adjusted by a qualified serviceman.
- d. Condensate Disposal:
The drain pan below the evaporator serves to collect and direct the condensate to the evaporator pan located below the unit. Air flow over the pan hastens condensate evaporation so that external drain plumbing is not required.
- e. Freezer Defrost System:
The defrost timer is factory set for (3) twenty minute defrosts per 24 hour period. The start time for defrosting should be set to occur during lightest usage of cabinet. Choose defrost time desired and turn adjusting cam until defrost is activated. The defrost will then occur every eight hours. The adjusting cam is located on the instrument panel behind the inside light. (See Fig. 3) NOTE: Defrost timer on freezer models only.

3. MAINTENANCE:

- a. Cleaning Cabinet Exterior:
Cabinets should be cleaned with a solution of mild soap and water. Do not use caustic soap or abrasive cleaners, since these might damage the cabinet finish. If stainless steel surface becomes discolored, scrub by rubbing only in the direction of the finish grain. Do not use steel wool.
- b. Cleaning Interior Surface:
The inside of the cabinet is coated with baked-on paint (except stainless steel cooler). To clean, use mild soapy water and cloth or sponge.
- c. Condenser:
For efficient operation, it is recommended that the condenser coil and fans be cleaned every 3 to 6 months. Remove rear grille for access. Vacuum clean front surface of coil thoroughly or direct forced air through condenser fins. Failure to clean condenser can cause compressor malfunction and will void warranty.
- d. Evaporator Pan:
Evaporator pan should be cleaned periodically to prevent odors and maintain evaporating efficiency.
- e. Evaporator Fan:
To clean evaporator fan, disconnect power. Remove sign frame. Unlatch lid locks on front and back of lid and remove. Lift up on evaporator fan and shroud assembly to expose evaporator fan for cleaning.
- f. Temperature Control/Defrost Control:
Located behind front light in instrument panel assembly. Remove panel by loosening #10-32 thumb screw. This will expose temperature control and defrost timer. (See Fig. 3)

ILA-1595



BEVERAGE-AIR

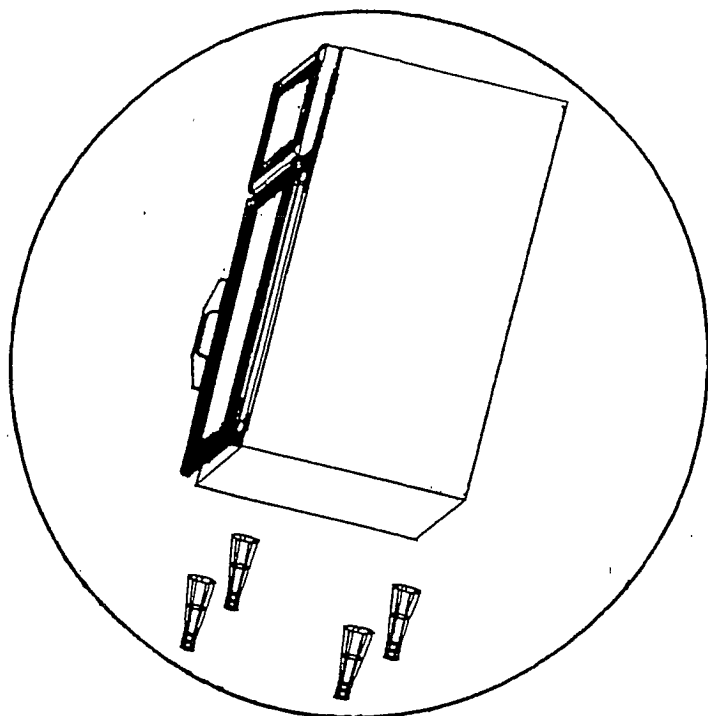

Fig. 1

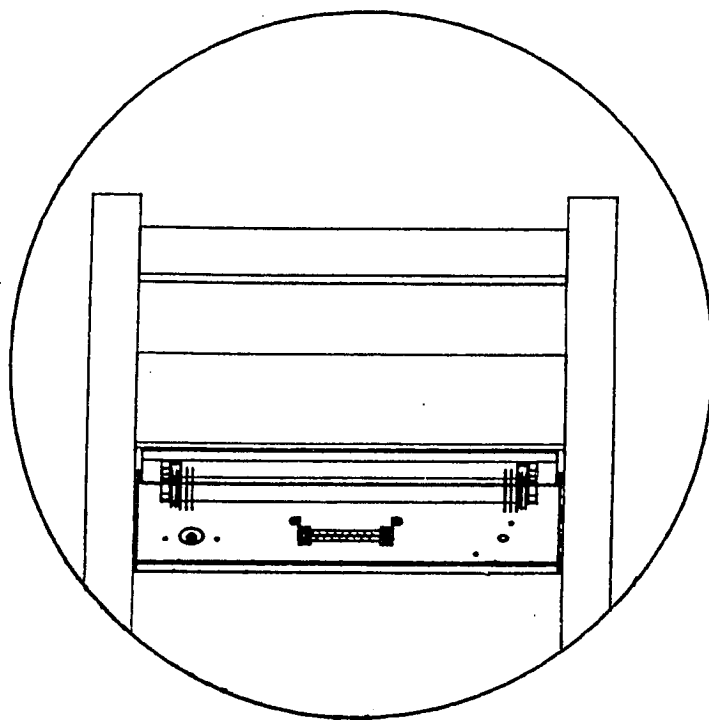

Fig. 2

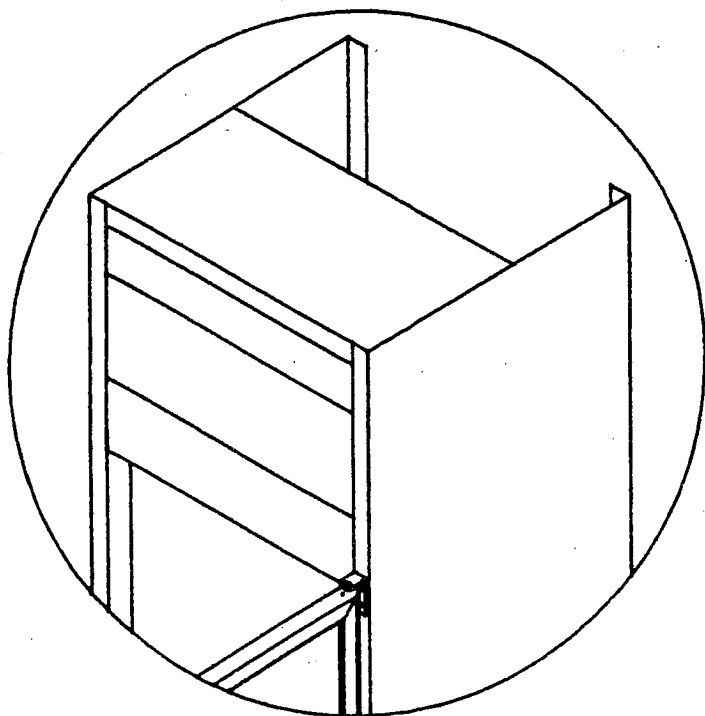
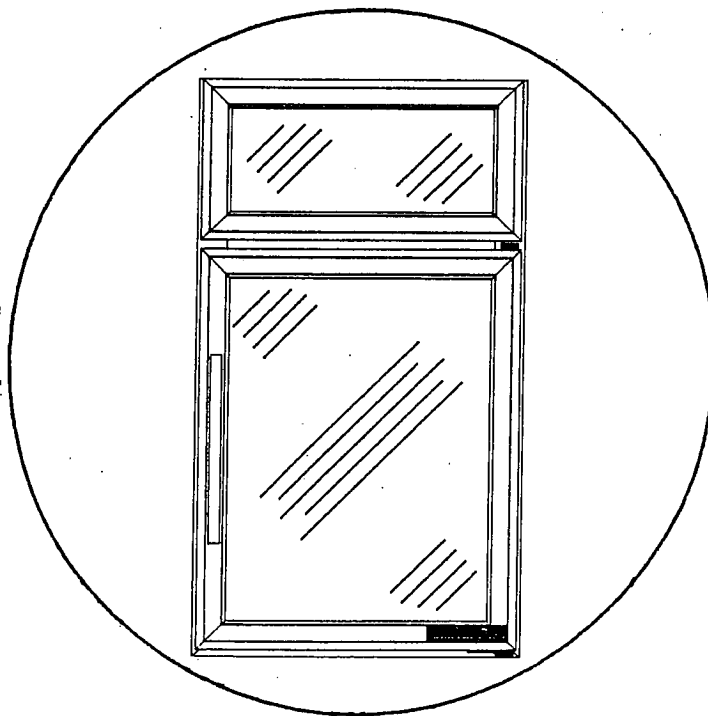

Fig. 3



SEAL CABINET TO COUNTER TOP AROUND BASE
FOR NSF REQUIREMENTS USING DOW CORNING #732
OR CLEAR RTV BEVERAGE AIR P/N. 704-134A (AS REQ'D.)

Fig. 4

SERVICE AND ANALYSIS CHART

REFRIGERATION SYSTEM

MALFUNCTION	POSSIBLE CAUSE	SOLUTION
Compressor will not start — no hum	<ol style="list-style-type: none"> 1. Line cord not plugged in. 2. Fuse removed or blown. 3. Overload protector tripped. 4. Control stuck in open position. 5. Wiring improper or loose. 	<ol style="list-style-type: none"> 1. Plug in line cord. 2. Replace fuse. 3. Refer to electrical section. 4. Repair or replace control. 5. Check wiring against diagram.
Compressor will not start — hums but trips on overload protector	<ol style="list-style-type: none"> 1. Improperly wired. 2. Low voltage to unit. 3. Starting capacitor defective. 4. Relay failing to close. 	<ol style="list-style-type: none"> 1. Check wiring against diagram. 2. Determine reason and correct. 3. Determine reason and replace. 4. Determine reason and correct, replace if necessary.
Compressor starts, but does not switch off of start winding	<ol style="list-style-type: none"> 1. Low voltage to unit. 2. Relay failing to open. 3. Run capacitor defective. 4. Compressor motor has a winding open or shorted. 	<ol style="list-style-type: none"> 1. Determine reason and correct. 2. Determine reason and correct, replace if necessary. 3. Determine reason and replace. 4. Replace compressor.
Compressor starts and runs, but short cycles on overload protector	<ol style="list-style-type: none"> 1. Additional current passing through overload protector. 2. Low voltage to unit. 3. Overload protector defective. 4. Run capacitor defective. 5. Excessive discharge pressure. 6. Compressor too hot — return gas hot. 	<ol style="list-style-type: none"> 1. Check wiring diagram. Check for added fan motors, pumps, etc., connected to wrong side of protector. 2. Determine reason and correct. 3. Check current, replace protector. 4. Determine reason and replace. 5. Check ventilation, restrictions in cooling medium, restrictions in refrigeration system. 6. Check refrigerant charge (fix leak) add if necessary.
Unit runs OK, but short cycles	<ol style="list-style-type: none"> 1. Overload protector. 2. Cold control. 3. Overcharge. 4. Air in system. 5. Undercharge. 	<ol style="list-style-type: none"> 1. Check wiring diagram. 2. Differential set too close — widen. 3. Reduce refrigerant charge. 4. Purge and recharge. 5. Fix leak, add refrigerant.
Unit operates long or continuously	<ol style="list-style-type: none"> 1. Shortage of refrigerant. 2. Control contacts stuck or frozen closed. 3. Evaporator coil iced. 4. Restriction in refrigeration system. 5. Dirty condenser. 	<ol style="list-style-type: none"> 1. Fix leak, add charge. 2. Clean contacts or replace control. 3. Defrost. 4. Determine location and remove. 5. Clean condenser.
Start capacitor open, shorted or blown	<ol style="list-style-type: none"> 1. Relay contacts not opening properly. 2. Low voltage to unit. 3. Improper relay. 	<ol style="list-style-type: none"> 1. Clean contacts or replace relay if necessary. 2. Determine reason and correct. 3. Replace.
Run capacitor open, shorted or blown	<ol style="list-style-type: none"> 1. Improper capacitor. 2. Excessively high line voltage. (110% or rated-max.) 	<ol style="list-style-type: none"> 1. Determine correct size and replace. 2. Determine reason and correct.
Relay defective or burned out	<ol style="list-style-type: none"> 1. Incorrect relay. 2. Line voltage too high or too low. 3. Relay being influenced by loose vibrating mounting. 	<ol style="list-style-type: none"> 1. Check and replace. 2. Determine reason and correct. 3. Remount rigidly.
Space temperature too high	<ol style="list-style-type: none"> 1. Control setting too high. 2. Improper overcharge. 3. Inadequate air circulation. 	<ol style="list-style-type: none"> 1. Reset control. 2. Purge. 3. Improve air movement.
Cooler freezing beverage	<ol style="list-style-type: none"> 1. Control setting. 	<ol style="list-style-type: none"> 1. Reset control.
Unit noisy	<ol style="list-style-type: none"> 1. Loose parts or mountings. 2. Tubing rattle. 3. Bent fan blade causing vibration. 4. Fan motor bearings worn. 	<ol style="list-style-type: none"> 1. Find and tighten. 2. Reform to be free of contact. 3. Replace blade. 4. Replace motor.



BEVERAGE-AIR®

SALES OFFICE: P.O. BOX 5932, SPARTANBURG, SOUTH CAROLINA 29304
 PLANTS: SPARTANBURG, SOUTH CAROLINA • BROOKVILLE, PENNSYLVANIA
 PHONE 803-582-8111 TOLL FREE NUMBER 1-800-845-9800

ILA-1591

REFRIGERATION SYSTEM

SERVICE AND ANALYSIS CHART

REFRIGERATION SYSTEM

The Refrigeration System consists of a 115v. 60 hz. hermetically sealed compressor, finned evaporator and condenser. All models are forced air, with lift out refrigeration system.

CONDENSER

The condenser has wide finned spaces which allow more air passage with less dirt or dust accumulation. The condenser still requires periodic cleaning for maximum efficiency.

CONDENSER FAN MOTOR

The condenser fan motor assembly is mounted between the condenser and compressor. Air is drawn through the condenser, over the body of the compressor and then out the rear of the unit compartment.

The motor is wired to cycle with the compressor but will continue to operate should the compressor cut out on the overload. (The motor is permanently lubricated; therefore, oiling is not required).

DRIER

The drier is installed in the system just before the capillary tube. Its purpose is to trap minute particles of foreign material and absorb any moisture in the system.

LIQUID CONTROL AND HEAT EXCHANGE

Liquid refrigerant control to the evaporator of the system is accomplished by the use of a capillary tube. This capillary tube is soldered to the suction line to form a heat exchanger which subcools the liquid refrigerant to maintain high efficiency within the system. Some freezers may be equipped with expansion valves.

REFRIGERATION SERVICE

EVACUATION

Moisture in a refrigeration system is directly or indirectly the cause of more problems and complaints than all other factors combined.

When large amounts are present, system freeze ups will occur. Even in minute amounts, moisture will combine with refrigerants to form acids. The corrosive action of this acid forms sludge which will plug the lines and drier.

Only a vacuum pump should be used for evacuation because operating the compressor in a deep vacuum could cause serious damage to the compressor windings.

Since most field type vacuum pumps cannot pull a low enough vacuum to remove moisture from the system, it is recommended that the system be triple evacuated, breaking each time with dry refrigerant. Use care to purge air from the charging hose when breaking the vacuum. After third vacuum, backseat valves, proceed with replacement charge.

CHARGING REFRIGERATION SYSTEM

Since capillary tube systems have small critical refrigerant charges, we recommend that a field charge either be weighed in or put in from a portable charge board. After maximum vacuum has been obtained as detailed above, attach charging cylinder to the suction line making sure to purge air from hose with refrigerant. With the unit running, allow refrigerant to run slowly into the system until the desired charge is reached.

OVERCHARGE

When the cabinet has pulled down to operating temperature an indication of an overcharge is that the suction line will be cooler than normal with the compressor running. Running time will be higher than normal. Suction line will sweat or frost.

Purge excessive refrigerant from the system very carefully in small amounts waiting several minutes for the system to balance.

When correct charge has been obtained with cabinet at operating temperature, several seconds after compressor has started after cycle, suction line will frost and remain frosted for approximately (60) seconds.

UNDERCHARGE

An undercharge or shortage of refrigerant will result in any or all of the following:

1. Lower than normal head pressure.
2. Lower than normal suction pressure.
3. Excessive or continuous operation of compressor.
4. Higher than normal cabinet temperature.

Effective Methods for Cleaning Stainless Steel

	Cleaning Agent*	Method of Application**	Effect on Finish
Routine Cleaning	Soap or ammonia, or detergent and water.	Sponge with cloth, then rinse with clear water and wipe dry.	Satisfactory for use on all finishes.
Smears and Fingerprints	Arcal 20, Lac-O-Nu, Lumin Wash O'Cedar Cream Polish, Stainless Shine.	Rub with cloth as directed on the package.	Satisfactory for use on all finishes. Provides barrier film to minimize prints.
Stubborn Spots and Stains, Baked-On Splatter, and Other Light Discolorations	Allchem Concentrated Cleaner.	Apply with damp sponge or cloth	Satisfactory for use on all finishes.
	Samae, Twinkle or Cameo Copper Cleaner.	Rub with damp cloth.	Satisfactory for use on all finishes if rubbing is light.
	Grade FFF Italian pumice, whitening, or talc.	Rub with damp cloth.	Use in direction of polish lines on No. 4 (polished) finish. Use light pressure on No. 2 (mill) finishes, and Nos. 7 and 8 (polished) finishes.
	Liquid NuSteal.	Rub with dry cloth. Use small amount of cleaner.	Use in direction of polish lines on No. 4 (polished) finish. May scratch No. 2 (mill) and Nos. 7 and 8 (polished) finishes.
	Paste NuSteal or DuBois Temp.	Rub with dry cloth using a small amount of cleaner.	Use in direction of polish lines on No. 4 (polished) finish. May scratch No. 2 (mill) and Nos. 7 and 8 (polished) finishes.
	Copper's Stainless Steel Cleaner Revere Stainless Cleaner.	Apply with damp sponge or cloth.	Use in direction of polish lines on No. 4 (polished) finish. May scratch No. 2 (mill) and Nos. 7 and 8 (polished) finishes.
	Household cleansers, such as Old Dutch, Lighthouse, Sunbrite, Wyandotte, Bab-O, Gold Dust, Sapolio, Bon Ami, Ajax, or Comet.	Rub with a damp cloth. May contain chlorine bleaches. Rinse thoroughly after use.	Use in direction of polish lines on No. 4 (polished) finish. May scratch No. 2 (mill) and Nos. 7 and 8 (polished) finishes.
	Grade F Italian pumice, Steel Bright, Lumin Cleaner, Zud, Restoro, Sta-Clean, or Highlite.	Rub with a damp cloth.	Use in direction of polish lines on No. 4 (polished) finish. May scratch No. 2 (mill) and Nos. 7 and 8 (polished) finishes.
Heat Tint or Heavy Discoloration	Penny-Brite or Copper-Brite.	Rub with a dry cloth.	Use in direction of polish lines on No. 4 (polished) finish. May scratch No. 2 (mill) and Nos. 7 and 8 (polished) finishes.
	Past NuSteel, DuBois Temp, or Tarnite.	Rub with a dry cloth or stainless steel wool.	Use in direction of polish lines on No. 4 (polished) finish. May scratch No. 2 (mill) and Nos. 7 and 8 (polished) finishes.
	Revere Stainless Steel Cleaner.	Apply with damp sponge or cloth.	Use in direction of polish lines on No. 4 (polished) finish. May scratch No. 2 (mill) and Nos. 7 and 8 (polished) finishes.
	Allen Polish, Steel Bright, Wyandotte, Bab-O, or Zud.	Rub with a damp cloth.	Use in direction of polish lines on No. 4 (polished) finish. May scratch No. 2 (mill) and Nos. 7 and 8 (polished) finishes.
Burnt-On Foods and Grease Fatty Acids; Milkstone (where swabbing or rubbing is not practical)	Easy-Off, De-Grease-It, 4 to 6% hot solution of such agents as trisodium phosphate or sodium tripolyphosphate or 5 to 15% caustic soda solution.	Apply generous coating. Allow to stand for 10-15 minutes. Rinse. Repeated application may be necessary.	Excellent removal, satisfactory for use on all finishes.
Tenacious Deposits, Rusty Discolorations, Industrial Atmospheric Stains	Oakite No. 33, Dilac Texo 12, Texo N. Y., Flash-Klenz, Caddy Cleaner, Turco Scale 4368 or Permag 57.	Swab and soak with clean cloth. Let stand 15 minutes or more according to directions on package, then rinse and dry.	Satisfactory for use on all finishes.
Hard Water Spots and Scale	Vinegar.	Swab or wipe with cloth. Rinse with water and dry.	Satisfactory for all finishes.
	5% oxalic acid, 5% sulfamic acid, 5 to 10% phosphoric acid, or Dilac, Oakite No. 33, Texo 12, Texo N. Y.	Swab or soak with cloth. Let stand 10-15 minutes. Always follow with neutralizer rinse, and dry.	Satisfactory for all finishes. Effective on tenacious deposits or where scale has built up.

NOTES:

- Use of proprietary names is intended only to indicate a type of cleaner, and does not constitute an endorsement, nor is omission of any cleanser to imply its inadequacy. It should be emphasized that all products should be used in strict accordance with instructions on package.
- In all applications a stainless steel wool or sponge or fibrous brush or pads are recommended. Avoid use of ordinary steel wool or steel brushes for scouring stainless steel.

SUGGESTIONS:

- Use the mildest cleaning procedure that will do the job effectively.
- Rub in the direction of polish lines for maximum effectiveness and to avoid marring the surface.
- Rinse thoroughly with fresh water after every cleaning operation.
- Wipe dry to avoid water marks.

Cleaning data supplied by AISI

Reprinted Courtesy by The House of Stainless, Inc., Chicago, Ill.



BEVERAGE-AIR.

Spartanburg, South Carolina
Brookville, Pennsylvania

ILA-1265
Instructions for SS Cleaning

